



HyperTransport Bridge



PRODUCT BRIEF

Overview Features

High-Speed Low-Latency Point-to-Point Link

HyperTransport technology is a high-speed, low-latency, point-to-point link for interconnecting integrated circuits (ICs) on a board. It is a packet-based link implemented on two independent uni-directional sets of wires. HyperTransport bridge is a popular topology with one primary link and one or more secondary links which allows to create an IO chain, connecting multiple I/O devices to a host system.

GDA's HyperTransport Bridge core, code named HyperBridge, is designed for reuse and it's flexible backend interface makes it easy to be integrated into wide range of applications. The core bridges two chains through one primary link and one secondary link, and provides highly scalable upstream and downstream bandwidths through programmable link widths and frequencies.

HyperBridge core meets today's demand for the increased bandwidth and offers more bandwidth than any existing solutions. The upstream link could be run 24 times faster than a 32 bit, 33 MHz PCI bus. The core is designed to operate the upstream link at up to 800 MHz DDR, yielding an effective transfer rate of 1.6 Gbits per second per wire pair. The design targets networking, tele-communications, embedded systems and any application where high speed, low latency response, low pin counts and scalability are necessary.

- Compliant with HyperTransport I/O Link Specification, Ver. 1.03
- Provides one primary link and one secondary link
- Either link can be hardware configured for 16-bit or 8-bit link interface
- Either link supports software programmable link widths of 16, 8, 4, or 2 bits
- Either links supports 800, 600, 500, 400, or 200 MHz link frequency
- Maximum bandwidth is 6.4 GB/sec on both links
- Supports independent link width and frequency for each link
- Supports peer-to-peer transactions
- Supports reset generation
- Supports interrupt
- Supports link disconnect protocol
- Supports external and internal loop backs
- Optional transaction interface provides target and initiator interfaces
- Optional packet interface for network applications

HT Bridge Core

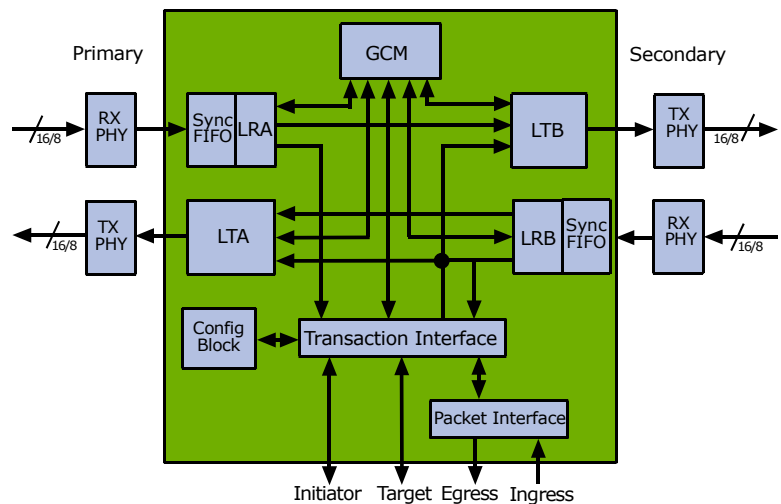

GDA Technologies, Inc
accelerate your innovation™



HyperTransport Bridge

Visit: www.gdatech.com

Call: 408.432.3090

Fax: 408.432.0660

email: ip@gdatech.com

Write: **GDA Technologies**
2071 Junction Ave
San Jose, CA 95131

Status : Bronze [under development]

Availability : June 2002

Language : Verilog HDL

Synthesis : Design Compiler

Simulation : Verilog-XL/NC, VCS

Technology : 0.18u Standard Cell

Specifications

Configurable Options

- Link Widths: 16/8 bits
- Back-end interface can be configured to transaction interface or packet interface mode
- Transaction interface can be configured to support target interface only
- Configurable buffer size for each virtual channel
- Configurable number of outstanding peer-to-peer non-posted requests

Design Attributes

- Highly modular design
- Fully synchronous, technology-independent design
- 128-bit wide internal data path
- Most part of the Bridge logic operates at 200 MHz core clock
- Clearly demarked clock domains
- Active-low asynchronous reset

Product Package

- RTL code
- Detailed design document
- Verification environment
- Test cases
- Synthesis environment/scripts

Documentation

- User manual
- Verification guide
- Synthesis guide

GDA Technologies reserves the right to change this document without prior notice and disclaim all warranties. It is the recipient's duty to confirm with GDA Technologies' Engineering Department specifications before proceeding with a product design. This document is confidential and should not be reproduced without GDA Technologies approval.

GDA Technologies, Hypertransport Bridge Core, HyperBridge and the GDA Technologies logo are trademarks of GDA Technologies, Inc. Patents and Patents pending.

©2002 GDA Technologies, Inc. San Jose, CA. All rights reserved.

June 2002 Version 1.0

www.gdatech.com



GDA Technologies, Inc
accelerate your innovation™

